

PwC New Zealand Economics Competition

2005 Question Paper Thursday, 19th May 2005

Instructions:

1. Do not open this booklet until instructed by your teacher
2. You have **fifty minutes** to answer all **forty questions**
3. Pencils and erasers only are permitted
4. Read all instructions in the Response Sheet provided
5. Mark your answers using **pencil only** on the Response Sheet
6. All questions are of equal value
7. Choose the **most correct** option to the question and colour in the corresponding oval on the Response Sheet
8. **One mark** will be awarded for each correct response
9. Avoid random guessing, as **one quarter** of a mark will be deducted for each incorrect answer
10. PLEASE MAKE SURE YOU FILL IN YOUR NAME CORRECTLY ON THE RESPONSE SHEET. ANY MISTAKES YOU MAKE WILL APPEAR ON YOUR CERTIFICATE



Question 1

The diagram below is a circular flow model for a closed economy. Which sector is the financial sector?

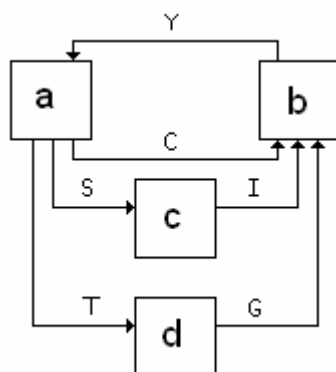

Questions 2 and 3 refer to the following table, which shows the production possibilities of two countries using the same quantity of resources.

	Country A	Country B
Clothes	40	80
Food	20	160

Question 2

Country B has an absolute advantage in:

- (a) Food
- (b) Clothes
- (c) Neither Food nor clothes
- (d) Both Food and Clothes

Question 3

According to the theory of comparative advantage, which would most likely occur?

- (a) Country B will export clothes
- (b) Country B will import food
- (c) They won't trade
- (d) Country A will export clothes

Question 4

Which of the following positions on a Production Possibility Curve would represent the highest degree of efficiency?

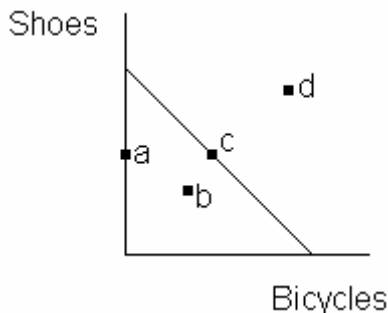

Questions 5 and 6 refer to the following table, which represents a closed economy. Assume that Taxation = Government Expenditure.

Income	\$400
Consumption	\$?
Investment	\$50
Savings	\$50
Government Expenditure	\$100

Question 5

What is the total value of consumption in this economy?

- (a) \$200
- (b) \$250
- (c) \$300
- (d) \$600

Question 6

If a \$100 increase in the disposable income in this economy results in an increase in savings of \$11, what is the marginal propensity to consume (MPC)?

- (a) 1.61
- (b) 0.99
- (c) 0.89
- (d) 0.11

Question 7

Which of the following economics concepts suggests that two economies will always benefit from free trade with each other?

- (a) Comparative advantage
- (b) Market failure
- (c) The paradox of thrift
- (d) The natural rate of unemployment

Question 8

Which of the following is an opportunity cost of walking to the supermarket rather than catching a bus?

- (a) The bus fare charged for catching the bus
- (b) The cost of the groceries purchased at the supermarket
- (c) The extra travel time it takes to walk to the supermarket compared to taking a bus
- (d) All of the above

Question 9

The definition of the Consumer Price Index (CPI) is:

- (a) A measure of the overall cost of the goods and services bought by a typical consumer
- (b) The percentage change in the price level from the preceding period
- (c) A measure of the cost of a basket of goods and services bought by firms
- (d) A measure of the overall cost of all goods and services available on the market

Question 10

Ticket sales surged for the 'Million Dollar Baby' movie following its winning of the Oscar for best picture. Which of the following best illustrates this?

- (a) The supply curve for the 'Million Dollar Baby' movie shifted to the right
- (b) The supply curve for the 'Million Dollar Baby' movie shifted to the left
- (c) The demand curve for the 'Million Dollar Baby' movie shifted to the right
- (d) The demand curve for the 'Million Dollar Baby' movie shifted to the left

Question 11

Using the hypothetical data in the following table, which of the following statements is true?

Year	Price of a Return Ferry Ride to Waiheke Island	Consumer Price Index (CPI)
1995	\$18	1000
2005	\$20	1200

- (a) The real price of this ferry trip has remained constant over this 10-year period
- (b) The real price of this ferry trip has increased over this 10-year period
- (c) The real price of this ferry trip has decreased over this 10-year period
- (d) There is insufficient information in this table to determine what has happened to the real price of this ferry trip

Question 12

In a particular market, the demand for oranges increases, while the supply of oranges decreases. Which of the following statements best describes what will happen in this market?

- (a) The price of oranges will rise, and the quantity sold will fall
- (b) The price of oranges will rise, and the quantity sold will rise
- (c) The price of oranges will rise, with an unknown effect on the quantity sold
- (d) The quantity of oranges sold will rise, with an unknown effect on the price

Question 13

For two countries that are planning to trade, each producing two identical goods, it is impossible for one of the countries to:

- (a) Have a comparative advantage in both goods
- (b) Have an absolute advantage in both goods
- (c) Completely specialise in the production of the good they export
- (d) Trade so that people in both countries will be better off

Question 14

Structural unemployment is caused by:

- (a) Social welfare policies that discourage people from taking available jobs
- (b) Recessions
- (c) A growing share of employment in the public sector
- (d) Mismatches between the skills of job seekers and skills sought by employers with job vacancies

Question 15

The Phillips Curve shows the possible trade-off between:

- (a) Efficiency and equity
- (b) Interest rates and inflation
- (c) Unemployment and inflation
- (d) Unemployment and economic growth

Question 16

In economics, which of the following is considered as savings?

- (a) A farmer buys a new tractor at a 50% discount
- (b) A student buys \$100 worth of textbooks
- (c) A worker puts \$500 of his wage into a term deposit
- (d) A computer store invests in a new accounting system

Question 17

Like most other developed economies, the official unemployment rate in New Zealand is:

- (a) The number of people in the labour force divided by the number of people in the working age population
- (b) The number of people without jobs who are actively seeking employment divided by the number of people in the labour force
- (c) The number of people without jobs who are actively seeking employment divided by the working age population
- (d) The number of people receiving a social welfare benefit divided by working age population

Question 18

Stagflation occurs when unemployment and inflation are both high in the short run. Which of the following would result in stagflation?

(a)

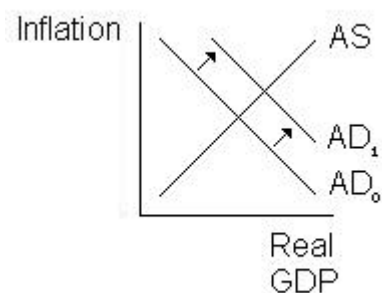

(b)

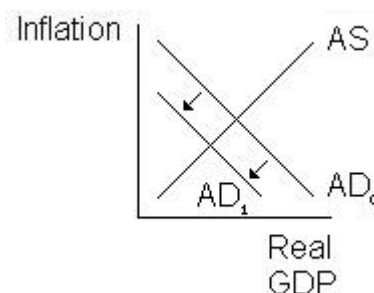

(c)

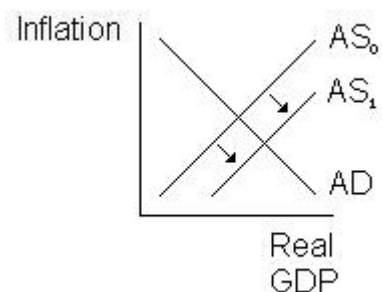

(d)

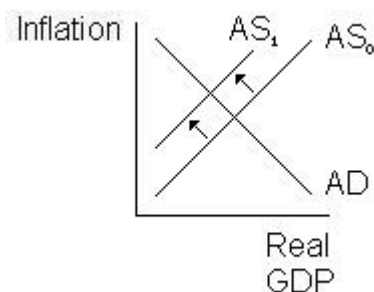

Question 19

Which of the following statement best describes New Zealand's recent history on the unemployment rate?

- (a) The unemployment rate has remained relatively steady at between 8% and 9% since the late 1990s
- (b) The unemployment rate has been steadily increasing since the late 1990's, and is now over 10%
- (c) The unemployment rate has fluctuated considerably since the late 1990's, but is now slightly under 6%
- (d) The unemployment rate has declined steadily since the late 1990's, and is now slightly under 4%

Question 20

Elastic demand for a good means that:

- (a) A 10% increase in the price for that good will lead to more than a 10% decrease in the quantity sold
- (b) A 10% increase in income will lead to more than a 10% increase in the quantity of the good demanded
- (c) Any increase in the price for that good will increase the total expenditure on that good
- (d) Both (a) and (c) are correct

Question 21

MC Screwdriver is a famous pop star. His newest album, *Can't see this*, isn't selling as well as he had initially hoped. Which of the following has the potential to shift the demand curve for his album to the right?

- (a) A reduction in the price of the album
- (b) A doubling in the number of albums produced
- (c) An increase in the amount of advertising for his album
- (d) All of the above

Question 22

If there is an increase in the price of imported goods into New Zealand, then which of the following statements is true?

- (a) This will tend to increase the Consumer Price Index (CPI), but not the Gross Domestic Product (GDP) deflator
- (b) This will tend to increase the GDP deflator, but not the CPI
- (c) This will tend to increase both the CPI and GDP deflator
- (d) There will be no impact on either the CPI or GDP deflator

Question 23

The "Kyoto Protocol" is best described as:

- (a) A computer representation (developed by the Japanese in Kyoto) of the endogenous variables affecting the environment and its effect on developing nations
- (b) An agreement signed by a number of nations which commits developed economies that are also signatories to limit or reduce their greenhouse gas emissions
- (c) The commonly accepted method of exchanging commercial contracts by Japanese based companies
- (d) A very nice Japanese luxury car

Question 24

Changes in a country's standard of living over time are best measured by:

- (a) Changes in aggregate real Gross Domestic Product (GDP)
- (b) Changes in real GDP per capita
- (c) Changes in aggregate nominal GDP
- (d) Changes in nominal GDP per capita

Question 25

Which of the following statements about New Zealand's exchange rate is true?

- (a) The New Zealand dollar is allowed to freely float against other currencies, and has steadily appreciated against the US dollar in recent years
- (b) The New Zealand dollar is tightly controlled by the Reserve Bank, but has been allowed to appreciate in recent years against the US dollar
- (c) The New Zealand dollar is tightly controlled by the Reserve Bank, and has remained at exactly the same level against the US dollar
- (d) The New Zealand dollar is allowed to freely float against other currencies, and has steadily depreciated against the US dollar in recent years

Question 26

A situation where a country sells its exports at or below cost in foreign markets is known as:

- (a) A tariff
- (b) An export incentive
- (c) A local content rule
- (d) Dumping

Question 27

Dr Morgan is a university lecturer. When Dr Morgan buys a cup of coffee on Monday morning before work he is contributing to which part of national income?

- (a) Consumption
- (b) Investment
- (c) Government spending
- (d) Net exports

Question 28

The Official Cash Rate used by the Reserve Bank of Zealand:

- (a) Is the rate paid on funds deposited at the Reserve Bank
- (b) Is the main monetary policy tool in this country
- (c) Influences other interest rates in the economy (e.g. the 90-day rate)
- (d) All of the above are true

Question 29

The organization primarily responsible for regulating the competition between firms in New Zealand is:

- (a) The Treasury
- (b) The Reserve Bank
- (c) The Business Roundtable
- (d) The Commerce Commission

Question 30

Government tariffs have the effect of:

- (a) Encouraging global free trade
- (b) Protecting local industry from import competition
- (c) Redistributing income away from government and local producers to importers and consumers
- (d) Both (b) and (c) are correct

Question 31

If the Reserve Bank keeps the money supply constant during a recession, then:

- (a) The Reserve Bank Governor will automatically lose his or her job
- (b) Interest rates will likely rise
- (c) Interest rates will likely fall
- (d) Interest rates will likely remain constant

Question 32

Long term economic growth in developed economies is mainly dependent on the level of:

- (a) Inflation
- (b) Unemployment
- (c) Technology and innovation
- (d) Natural resources

Question 33

“Too many dollars chasing too few goods” is the short-form definition of:

- (a) Perfectly inelastic supply
- (b) Real economic growth
- (c) Productivity improvement
- (d) Inflation

Question 34

New Zealand is a member of which of the following organisations?

- (a) NAFTA
- (b) APEC
- (c) ASEAN
- (d) EU

Question 35

Which of the following is an example of an automatic stabiliser?

- (a) An increase in tax cuts
- (b) Government welfare payments
- (c) Donations to charity
- (d) All of the above

Question 36

The Terms of Trade (ToT) refer to:

- (a) The negotiations over tariffs and quotas between countries
- (b) The absolute advantages that countries possess in the production of the goods they export
- (c) The quantity of imports that can be financed with a given quantity of exports
- (d) The splitting of average transportation costs between countries

Question 37

ASEAN members include:

- (a) US, Japan, Australia, New Zealand, Hong Kong, Taiwan, Korea and China
- (b) Algeria, Gabon, Indonesia, Libya, Nigeria, Qatar, United Arab Emirates and Venezuela
- (c) US, Japan, Germany, France, UK, Italy and Canada
- (d) Singapore, Malaysia, Indonesia, Thailand, Philippines, Burma, Laos, Cambodia and Vietnam

Question 38

If air travel is a 'normal good', then:

- (a) All consumers will fly
- (b) An increase in income will increase the amount of flying done by consumers
- (c) A decline in the price of air travel will slightly increase the amount of flying done by consumers
- (d) A decline in the price of air travel will substantially increase the amount of flying done by consumers

Question 39

The Economist magazine uses an index called the "Big Mac Index" to calculate whether currencies are over or undervalued. It does this by taking the ratio of the price of a Big Mac in two different countries and comparing that to the official exchange rate. What economic theory is this based on?

- (a) Purchasing power parity
- (b) Keynesian demand theory
- (c) The no free lunch theory
- (d) Both (b) and (c) are correct

Question 40

Agriculture, fishing and forestry and logging together account for approximately what percentage of GDP in New Zealand?

- (a) Less than 1%
- (b) 10%
- (c) 30%
- (d) More than 50%

-- End of paper --

About the UNSW Commerce and Economics Society



The Commerce and Economics Society is a non-profit student organisation based at the University of New South Wales. One of its aims is to promote the study of Commerce and Economics by running such projects as the Business Studies Competition and the Economics Competition. The Society and its activities are run entirely by students on a voluntary basis with the generous support of the University and the business community.

Acknowledgments

The UNSW Commerce and Economics Society would like to acknowledge and sincerely thank the following organisations and individuals for providing support and input into the Competitions and, in particular, the development of the Competition questions.

Competition sponsors or active supporters:

- PricewaterhouseCoopers
- University of New South Wales
- Reserve Bank of Australia
- University of Auckland, New Zealand

University Staff:

Associate Professor Tim Maloney (University of Auckland)
Ms. Trish Marsters (University of Auckland)
Associate Professor Glen Otto (University of New South Wales)
Dr. David Morgan (University of New South Wales)

Contributors and Reviewers:

Maiyuran Arumugam	Cheuk Wang Chan
Elizabeth Dess	John Ho
Anita Hong	Adrian Lee
Winnie Lour	Janette Liu
Joe Liu	Anson Mak
James Minai	George Ng
Julie Oey	Nitesh Patel
Bambul Shakibaei	Matheepan Sivagnanasundaram
Lucy Zhou	

For more information about the PwC Economics and Business Studies Competitions, visit our website at **[www.studentcompetitions.org]**