

1. Economics is the study of how:
 - A. to fully satisfy our unlimited wants.
 - B. society manages its scarce resources.
 - C. to reduce our wants until we are satisfied.
 - D. society manages its unlimited resources.

2. You have spent \$1,000 building a hot-dog stand based on estimates of sales of \$2,000. The hot-dog stand is nearly completed, but now you estimate total sales to be only \$800. You should complete the hot-dog stand as long as the cost to do so is less than:
 - A. \$100
 - B. \$300
 - C. \$500
 - D. \$800

3. Trade-offs are required because wants are unlimited and resources are:
 - A. economical.
 - B. scarce.
 - C. unlimited.
 - D. marginal.

4. The diagram below is a circular flow model for a closed economy. Which sector is the financial sector?

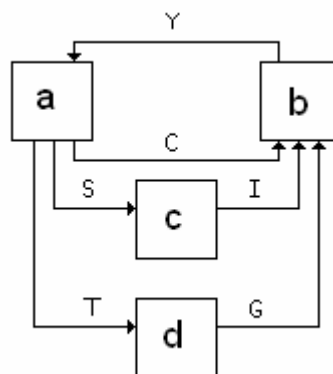

- A. a
- B. b
- C. c
- D. d

Questions 5 and 6 refer to the following table, which shows the production possibilities of two countries using the same quantity of resources.

	Thailand	Japan
Electronics	40	80
Food	20	160

5. Japan has an absolute advantage in:
- A. food.
 - B. electronics.
 - C. neither food nor electronics.
 - D. both food and electronics.
6. According to the theory of comparative advantage, which would most likely occur?
- A. Japan will export electronics.
 - B. Japan will import food.
 - C. They won't trade.
 - D. Thailand will export electronics.
7. Suppose there are three identical vases available to be purchased. Buyer 1 is willing to pay \$30 for one, buyer 2 is willing to pay \$25 for one, and buyer 3 is willing to pay \$20 for one. If the price is \$25, how many vases will be sold and what is the value of consumer surplus in this market?
- A. One vase will be sold, and consumer surplus is \$30.
 - B. One vase will be sold, and consumer surplus is \$5.
 - C. Two vases will be sold, and consumer surplus is \$5.
 - D. Three vases will be sold, and consumer surplus is \$0.
8. A free market fails to produce an efficient outcome if:
- A. it produces a side effect or externality.
 - B. there is only one producer, which is forced to charge a uniform price.
 - C. the sellers in the market know more about the quality of the good traded than the buyers.
 - D. All of the above is true.

Assume the Southland market for panel heaters is perfectly competitive. Let the demand in this market be described by $Q^D=22-2P$ and the supply by $Q^S=-6+2P$.

9. What is the equilibrium quantity given these demand and supply equations?
- A. 4
 - B. 6
 - C. 8
 - D. 10
10. What is the equilibrium price given these demand and supply equations?
- A. \$6
 - B. \$7
 - C. \$8
 - D. \$9
11. If the Southland Regional Council introduced a price ceiling of \$5 on the panel heater market, the quantity traded in that market would be:
- A. 4
 - B. 6
 - C. 8
 - D. 10
12. If the Southland Regional Council introduced a price ceiling of \$5 on the panel heater market, what is the marginal cost of the producer with the highest marginal cost who is still selling? (Choose the best answer.):
- A. \$5
 - B. \$7
 - C. \$9
 - D. any cost between \$5 and \$9
13. If the Southland Regional Council introduced a price ceiling of \$5 on the panel heater market, what value does the consumer, who values the unit he buys the least, attach to the unit he buys? (Choose the best answer.)
- A. \$5
 - B. \$7
 - C. \$9
 - D. any value between \$5 and \$9

14. In the short run, the competitive firm's supply curve:
- A. is the portion of the marginal-cost curve that lies above the average-total-cost curve.
 - B. is the portion of the marginal-cost curve that lies above the average-variable-cost curve.
 - C. is the upward-sloping portion of the average-total-cost curve.
 - D. is the upward-sloping portion of the average-variable-cost curve.
15. The long-run market supply curve:
- A. is always more elastic than the short-run market supply curve.
 - B. is always less elastic than the short-run market supply curve.
 - C. has the same elasticity as the short-run market supply curve.
 - D. is always perfectly elastic.
16. In the short run, the monopolist's supply curve:
- A. is the portion of the marginal-cost curve that lies above the average-total-cost curve.
 - B. is the portion of the marginal-cost curve that lies above the average-variable-cost curve.
 - C. is the upward-sloping portion of the average-variable-cost curve.
 - D. does not exist.
17. Which of the following statements about price discrimination is NOT true?
- A. Price discrimination requires that the seller be able to separate buyers according to their willingness to pay.
 - B. Perfect price discrimination generates a deadweight loss.
 - C. Price discrimination increases a monopolist's profit.
 - D. For a monopolist to engage in price discrimination, buyers must be unable to engage in arbitrage.
18. If the Commerce Commission breaks up a natural monopoly into many smaller firms, the cost of production:
- A. will fall.
 - B. will rise.
 - C. will remain the same.
 - D. could either rise or fall depending on the elasticity of the monopolist's supply curve.

19. Collusion is difficult for an oligopoly to maintain:
- A. because competition laws make collusion illegal.
 - B. because, in the case of oligopoly, self-interest is in conflict with cooperation.
 - C. if additional firms enter the oligopoly.
 - D. for all of the above reasons.
20. Bob and Tom live in a university dorm. Bob values playing loud music at a value of \$100. Tom values peace and quiet at a value of \$150. Which of the following statements is true about an efficient solution to this externalities problem if Bob has the right to play loud music and if there are no transactions costs?
- A. Bob will pay Tom \$100 and Bob will stop playing loud music.
 - B. Tom will pay Bob between \$100 and \$150 and Bob will stop playing loud music.
 - C. Bob will pay Tom \$150 and Bob will continue to play loud music.
 - D. Tom will pay Bob between \$100 and \$150 and Bob will continue to play loud music.
21. The Minister of Finance for New Zealand is
- A. Dennis Rodman.
 - B. Scottie Pippen.
 - C. Stephen Joyce.
 - D. Michael Jordan.
22. Gross domestic product can be measured as the sum of:
- A. consumption, investment, government purchases, and net exports.
 - B. consumption, transfer payments, wages, and profits.
 - C. investment, wages, profits, and intermediate production.
 - D. net national product, gross national product, and disposable personal income.
23. If nominal GDP in 2017 exceeds nominal GDP in 2016, then the production of output must have:
- A. risen.
 - B. fallen.
 - C. stayed the same.
 - D. risen or fallen because there is not enough information to determine what happened to real output.

24. In 2016, the New Zealand CPI was 1,214.0. In 2015, it was 1,198.0. What was the rate of inflation over this period?
- A. 1.1%
 - B. 1.3%
 - C. 2.3%
 - D. You can't tell without knowing the base year.
25. Suppose your income rises from \$19,000 to \$31,000 while the CPI rises from 1,220 to 1,690. Your standard of living has likely:
- A. fallen.
 - B. risen.
 - C. stayed the same.
 - D. You can't tell without knowing the base year.
26. Under which of the following conditions would you prefer to be the lender?
- A. The nominal rate of interest is 20% and the inflation rate is 25%.
 - B. The nominal rate of interest is 15% and the inflation rate is 14%.
 - C. The nominal rate of interest is 12% and the inflation rate is 9%.
 - D. The nominal rate of interest is 5% and the inflation rate is 1%.
27. Fonterra has the opportunity to purchase a new distribution centre in China today that will provide them with a \$50 million return four years from now. If prevailing interest rates are 6%, what is the maximum that the project can cost for Fonterra to be willing to undertake the project?
- A. \$39,604,683
 - B. \$43,456,838
 - C. \$50,000,000
 - D. \$53,406,002
28. Which of the following is an example of moral hazard?
- A. After Joe buys fire insurance, he begins to smoke cigars in bed.
 - B. Doug has been feeling poorly lately so he seeks health insurance.
 - C. Both Susan's parents lost their teeth due to gum disease, so Susan buys dental insurance.
 - D. All of the above demonstrate moral hazard.
29. A minimum-wage law tends to:
- A. create more unemployment in high-skill job markets than in low-skill job markets.
 - B. create more unemployment in low-skill job markets than in high-skill job markets.
 - C. have no impact on unemployment as long as it is set above the competitive equilibrium wage.
 - D. help all teenagers because they receive a higher wage than they would otherwise.

30. Unions might increase efficiency in the case where they:
- A. Raise the wage for insiders above the competitive equilibrium.
 - B. Offset the market power of a large firm in a "company town."
 - C. Lower the wage of local outsiders.
 - D. Threaten a strike but don't actually follow through, so there are no lost hours of work.
31. Suppose all banks maintain a 100 percent reserve ratio. If an individual deposits \$1,000 of currency in a bank:
- A. the money supply is unaffected.
 - B. the money supply increases by more than \$1,000.
 - C. the money supply increases by less than \$1,000.
 - D. the money supply decreases by more than \$1,000.
32. The Reserve Bank of New Zealand's main monetary policy tool is:
- A. the reserve ratio.
 - B. the discount rate.
 - C. the official cash rate.
 - D. the loan-to-value ratio.
33. At the end of 2016, the New Zealand dollar (NZD) could purchase 0.6974 US dollars (USD). If the NZD appreciated 1% relative to the USD in June 2017, then how many USD could the NZD buy in June 2017?
- A. 0.7043
 - B. 0.7074
 - C. 0.6904
 - D. 0.6874
34. If purchasing power parity holds, then the value of the:
- A. real exchange rate is equal to one.
 - B. nominal exchange rate is equal to one.
 - C. real exchange rate is equal to zero.
 - D. nominal exchange rate is equal to zero.
35. Suppose, due to Brexit, British banks build new headquarters in Paris so they can relocate to France. Which of the following is true regarding French net foreign investment?
- A. French net foreign investment rises.
 - B. French net foreign investment falls.
 - C. French net foreign investment is unchanged because only French residents can alter French net foreign investment.
 - D. None of the above is true.

36. In the model of aggregate demand and aggregate supply, the initial impact of an increase in consumer optimism is to:
- A. shift short-run aggregate supply to the right.
 - B. shift short-run aggregate supply to the left.
 - C. shift aggregate demand to the right.
 - D. shift aggregate demand to the left.
37. Suppose the British economy is initially in long-run equilibrium. Then, in the fallout of Brexit, continental Europeans leave Britain, together with their expertise. According to the model of aggregate demand and aggregate supply, what happens to prices and output in the short run?
- A. Prices rise; output rises.
 - B. Prices rise; output falls.
 - C. Prices fall; output falls.
 - D. Prices fall; output rises.
38. Suppose a wave of investor and consumer optimism has increased spending so that the current level of output exceeds the long-run natural rate. If policymakers choose to engage in activist stabilisation policy, they should:
- A. decrease taxes, which shifts aggregate demand to the right.
 - B. decrease taxes, which shifts aggregate demand to the left.
 - C. decrease government spending, which shifts aggregate demand to the right.
 - D. decrease government spending, which shifts aggregate demand to the left.
39. Which of the following statements regarding taxes is correct?
- A. Most economists believe that, in the short run, the greatest impact of a change in taxes is on aggregate supply, not aggregate demand.
 - B. A permanent change in taxes has a greater effect on aggregate demand than a temporary change in taxes.
 - C. An increase in taxes shifts the aggregate-demand curve to the right.
 - D. A decrease in taxes shifts the aggregate-demand curve to the left.
40. The misery index, which some commentators suggest measures the health of the economy, is:
- A. the sum of the growth rate of output and the inflation rate.
 - B. the sum of the unemployment rate and the inflation rate.
 - C. the sum of the NZX 50 Index and the Official Cash Rate.
 - D. the sum of the natural rate of unemployment and the actual rate of unemployment.